

EKG diagram with instructions

This is the wiring schematic for the EKG circuit that should be constructed:

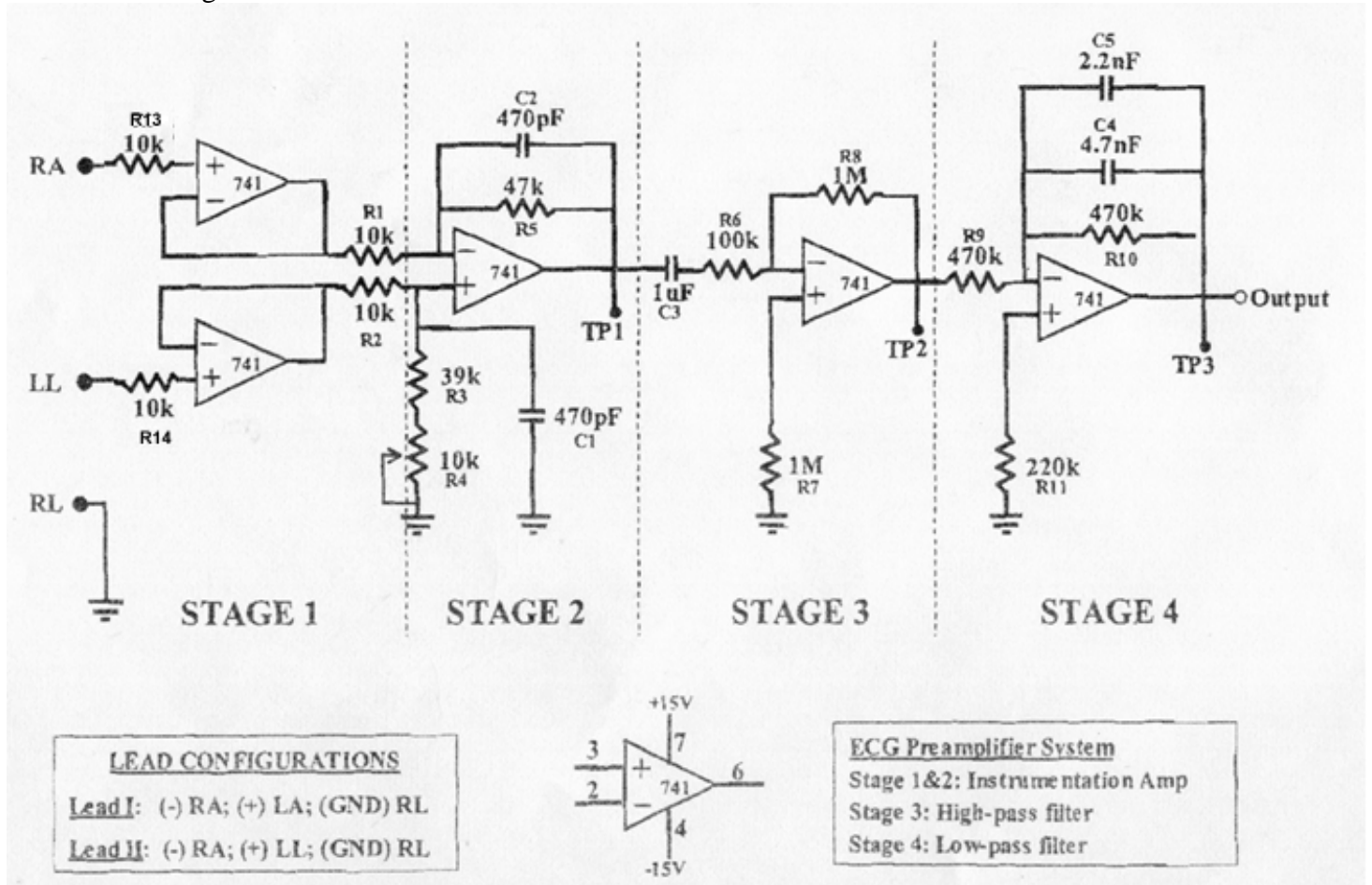

Prepare the circuit on a breadboard, arranging each stage as a separate section. It should look similar to this:

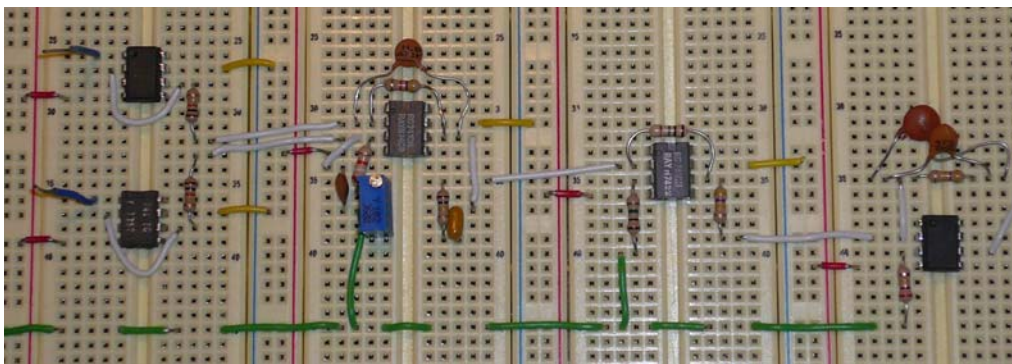

Each section or stage of the circuit should be covered with a module box like this:



Circuit Connections

The output from stage 4 of the circuit can be directly connected to an oscilloscope. The power source should be set at +15V and -15V and be connect to Each Op Amp, as showed in the diagram. Leads RA (Right Arm) and LL (Left Leg) can be directly attached to the bioelectrodes on the body. The Lead RL (Right Leg) can be directly connected to the body and to the common ground of the circuit.