

STOP THE STRETCHING!

DESIGNING AND TESTING COMPOSITE MATERIALS TO BE STRONG AND STIFF IN TENSION

by Douglas Prime and Lacey Prouty
Tufts University, Center for Engineering Educational Outreach
and Brad George
Hale Middle School, Nashoba Regional School District

Problem Statement

Because of the increasing cost of making plastic chair webbing (plastic strips), your company needs to find a new way to make lawn chairs. An idea was introduced to make strips out of plastic sheets, and develop a new product line. However the plastic alone is not strong enough in **tension**, and it stretches way too much to be used to make lawn chairs. Your team has been assigned to design and test a new **composite material** to use for chair webbing. A composite material is one that is made from one or more other materials bonded together. Your goal is to design a 3” wide strip of chair webbing made from thin plastic, masking tape, string, and hot glue. Your chair webbing must be designed to hold the greatest **load** possible in tension, with the smallest amount of **elongation** (stretch). Your team will develop and test two designs for chair webbing. Each design must be made only from the materials provided. The chair webbing test strips that you design and make must be 3” wide and 18” long.

Materials (needed for each team to make 1 test strip for 1 design. Each team will need 4 sets of materials, two for testing and two to keep for their records)

- 1 strip of plastic sheet, 4 mils thick X 3” wide X 18” long
(1 mil = 1/1000 in.) – A roll of plastic sheeting -don't use trash bags
- 5’ of masking tape
- 5’ of thread

Tools

- rulers
- scissors
- marker
- scale to weigh sand or stones

Procedure

- 1) Your team must spend ten minutes brainstorming and making sketches of possible ways to design the chair webbing before you will be allowed to get materials.
- 2) Select the two designs that you believe to be the best, and make 2 sample strips of each chair web design – one to test and one to keep for your records.
- 3) With a marker, draw two lines on your test strip (see Figure 1) that are 5” apart (the lines must not be on the duct tape). These lines mark the initial length of your test strip. The ends of the strip that are covered with duct tape don’t count as part of the test length because the duct tape adds strength to the material.
- 4) Record the weight of the bottom bolt chain and bucket. This is the initial Load that will be placed on your test strip.
- 5) Place your team’s test strip in the testing device as shown: Tape a strip into the test fixture (see Figure 1). For each end, you will fold 3” of the strip over the bolt, and then place a 4” piece of duct tape vertically across the seam. Place another 5” piece of duct tape horizontally across the seam and fold it over to the other side of the test strip (it is important to tape in both directions to prevent the seam from breaking).

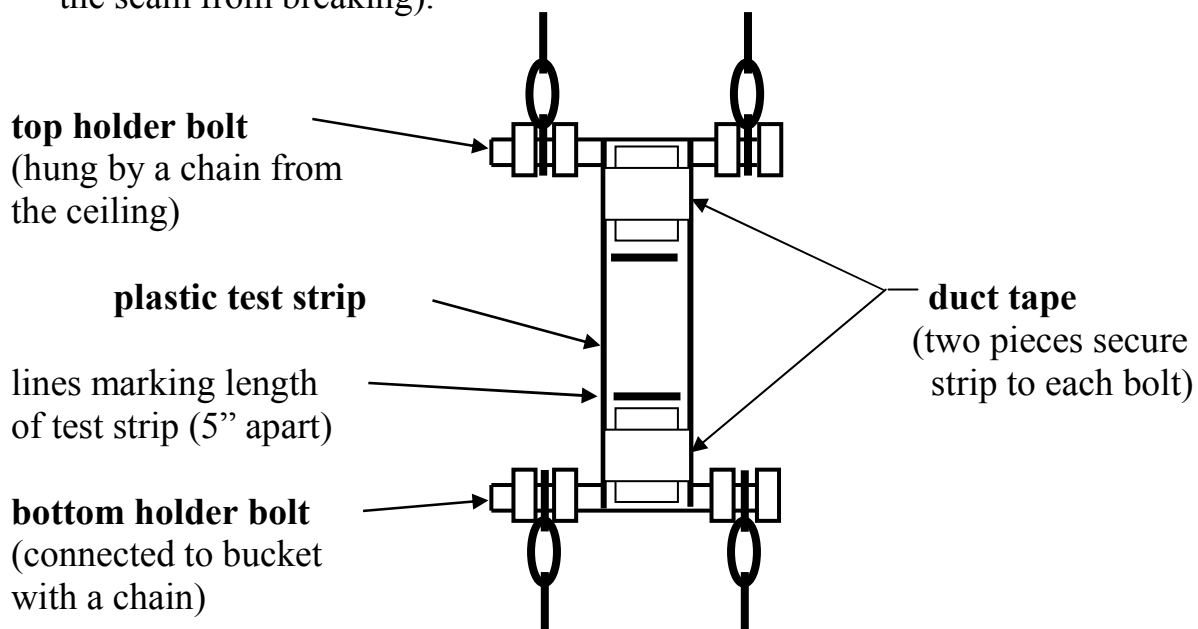

Figure 1: Mounting a Test Strip in the Test Fixture

- 6) Fill a small coffee can with peastones (or sand) and record the weight. The weight of the can should be subtracted from the total.
- 7) Pour two cans of peastones (or sand) into the pail and record the new length of the test strip in the table provided.
- 8) Repeat this procedure until the test strip breaks. Keep increasing the weight in the bucket two cans at a time, and recording the new length.
Make a tensile load (lbs) v. length (in.) graph for your test strip.

Repeat this test with your other design, and graph the results on the same graph as design #1.