

Edible Rovers Activity – High School – Edible Rover Worksheet – Geometry – **Answers**

Instructions

You have just been notified that NASA is planning to launch another Mars Rover Mission and you are going to design the rover. NASA has given you a budget of \$1,450,000 and provided you with several required parts for the rover; however, you must design a new body and select the instruments that will be mounted on the body. The body must weigh less than 16 kilograms and be able to support the instruments you plan on using. You have been given a list of four material types (Table 1), each with unique strengths, weights, and costs, to choose from for the body. Use your knowledge of Mars Rovers and mathematics to construct a rover that can effectively study Mars while meeting all of these requirements.

Material	Price (\$/sqr. m)	Strength (kg/sqr. m)	Weight(kg/sqr. m)
Funky Carbon	52500	8	4
Honeycomb Core	45000	8	4.75
Old School Steel	35000	6	5
Outer Space Aluminum	30000	5	4.5

Table 1: Available Materials for Body Construction

1. Describe a Mars rover's instrumentation. What scientific instrumentation can be found on a Mars rover and what does each instrument do?
Panoramic Camera, also known as the Pancam can rotate 360 degrees and is equipped with several types of cameras that take pictures at different wavelengths. The capabilities of the Pancam help scientists map out the areas the mars rover explores and determine if there was ever water on Mars. The Pancam is mounted on the neck of the rover.
Hazard Avoidance Cameras or Hazcams are used to help the Rover avoid crashing into objects on the surface of Mars. They are black and white cameras that use visible light to map out the road ahead and work with software to avoid any impassable objects. Hazcams are mounted on the front and back of the body of the Rover.
Navigation Cameras or Navcams are also used to help the rover navigate on the surface of Mars. These cameras are mounted on the neck of the rover and work with the Hazcams, providing a complimentary view of the terrain. Without the Navcams the rover's navigation capability would decrease greatly.
Microscopic Imager is a camera used to take extreme close-up shots of rocks and soil on Mars. The information gathered from these pictures is used to determine how soil

and rocks will impact rover mobility. This instrument is also used with the Rock Abrasion Tool to study the history of rocks. The Microscopic Imager is mounted on the arm of the rover.

Mössbauer Spectrometer is an instrument that was specially designed to measure and analyze iron-bearing minerals on Mars. It can accurately measure the abundance of these minerals in rocks, which among other things, gives scientists insight into the magnetic properties of the surface of Mars. The Mössbauer Spectrometer is mounted on the arm of the rover.

Rock Abrasion tool is a small drill used to drill holes in volcanic rocks on Mars. Then with the aid of the Microscopic Imager, it can be used to determine how rocks formed. This knowledge provides insight into the environmental conditions in which the rocks were formed. The Rock Abrasion Tool is mounted on the arm of the rover.

X-Ray Spectrometer uses x-rays to determine the chemical composition of rocks and soil on Mars. Knowledge of the composition of the rocks and soil will provide scientists with information about the formation of the Martian crust and any past weather patterns. The X-Ray Spectrometer is mounted on the arm of the rover.

If the students have not discussed the Mars instrumentation on this level of detail then the following would be more appropriate:

Visible Light Video Cameras help the rover maneuver around obstacles on Mars. They also allow scientists to map areas of Mars and study the geography for indications of Mars' past.

Scientific Cameras are used on the Mars rover to analyze the soil and rocks on Mars. Unlike the cameras used to map Martian geography, the scientific cameras are capable of seeing X-rays, ultraviolet light, and other forms of light besides visible light.

Drills are used to get a more extensive study of rocks and soil on Mars. By drilling holes in rocks and analyzing what's inside scientists can determine the environment in which the rock was created.

Antennas are used to relay information back to Earth. Since the rovers were created to eventually die on Mars all of the data they collect must be sent back to Earth via antennas.

2. Think about the Mars rover you are building. What will be the purpose of your rover? What capabilities should your rover have?

Allow the students to be creative here and have any kind of purpose they can think of, for example:

- a. To find water on Mars
 - The rover has to be able to navigate the Planet in order to find rock samples. Then it must be able to analyze the samples it finds. It also might need a powerful drill to drill deep down in the surface to try and find water below ground. There is no telling how long it could take collecting the data so the rover must be durable.
- b. To climb the highest mountain on Mars

- In this case the rover will have to be heavy and have an advanced navigation system. It will need all possible cameras and perhaps a drill in case it comes to an obstacle it cannot maneuver around. In order to perform all of the necessary maneuvering it will have to be well powered.
 - c. To study the weather patterns of Mars
 - The rover will need to be able to measure temperature, humidity, and wind speed. It will also need to be able to withstand severe weather conditions. It must have good navigation capabilities to measure weather patterns on other parts of Mars.
 - d. To find traces of aliens on Mars
 - The rover will need all types of cameras to navigate and detect foot prints or any form of chemicals left behind. It will also have to have the capability to excavate anything it finds. In case of an alien attack it will have to be able to quickly send information back to Earth, which will require the best available antennas.
 - e. Map out an entire hemisphere of Mars
 - This will need to be a lightweight, high-speed rover with a very sophisticated navigation program. It will also have to quickly map out areas. Even with the ability to travel at high speeds it will take a very long time to map a hemisphere of Mars, therefore it must be durable.
3. What instruments are you planning on using? Give a brief description of why for each one. How much will these instruments cost?

If the goal of a student's rover is to climb the highest mountain, the following instruments might be appropriate.

1. Panoramic Camera – The rover should have a Pancam to get a good view of what's ahead and map out the best course the rover can take.
2. Hazard Avoidance Cameras – Hazcams are entirely necessary if the rover is to have the best navigation system possible, which it needs since the rover will have to do most of the driving.
3. Navigation Cameras – The Nav cams will work with the Pan Cam to map out the optimal route for the rover.
4. Rock Abrasion tool – Some sort of drill is a must to allow the rover to get past otherwise impassable obstacles.
5. X-Ray Spectrometer – This tool will allow us to assess the composition of a rock, thereby determining how well the rock(s) can support the rover.
6. Mössbauer Spectrometer – It is always nice to have backup equipment in the case of unforeseen events. The spectrometer could act as a replacement to the X-Ray spectrometer if it breaks and provide insights into the composition of rocks on a more thorough level.

Cost: \$1,122,994

4. Draw the body of your rover in the space below. Be sure to include dimensions in your design. Also, keep in mind the mission constraints and the strength required to support the instruments you plan on using.

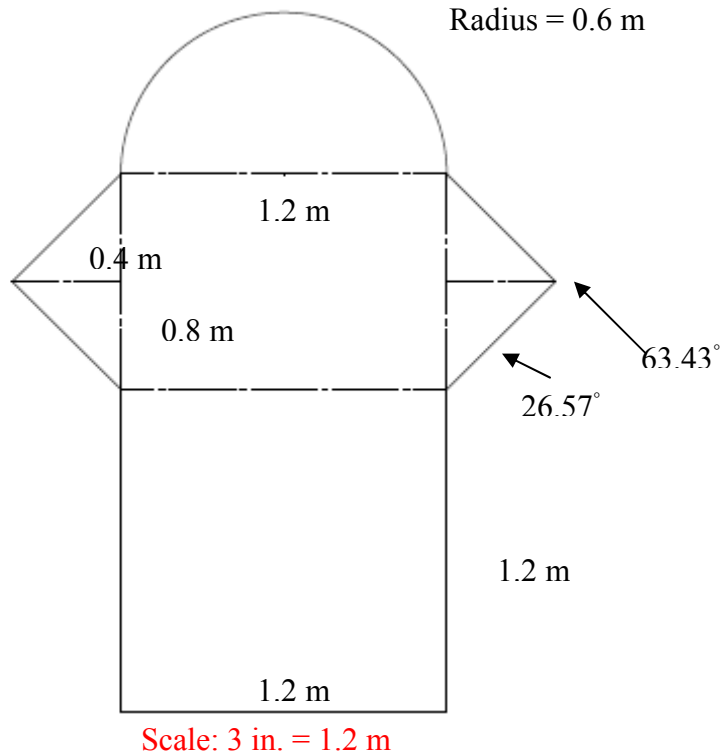

Note: The dotted lines are for finding the area.
 Students can use Sin, Cos, Tan, or their knowledge of triangles to determine angles.
 In the drawing above the broken up triangles are isosceles right triangles. Therefore they are composed of 45 and 90 degree angles.

5. Based on the dimensions of your design, how much material will you need for the body of your rover? (What is the area of the body of your rover?)

Area of Bottom Rectangle: $\text{Base} * \text{Height} = (1.2 * 1.2) = 1.44 \text{ m}^2$

Area of Top Rectangle: $\text{Base} * \text{Height} = (1.2 * 0.8) = 0.96 \text{ m}^2$

Area of Two Triangles: $2 * (\frac{1}{2} * \text{Base} * \text{Height}) = 2 * (\frac{1}{2} * 0.8 * 0.4) = 0.32 \text{ m}^2$

Area of half Circle: $\frac{1}{2} * \Pi * \text{Radius}^2 = \frac{1}{2} * \Pi * 0.6^2 = 0.565 \text{ m}^2$

Total Area: 3.285 m²

6. What is the perimeter of the body of your rover?

Bottom Half: $1.2 + 2 * 1.2 = 3.6 \text{ m}$

Two triangles: $4 * (\text{Length of Hypotenuse of isosceles right triangles})$

Pothagorean Theorem: $c^2 = a^2 + b^2$

$$\text{Hypotenuse} = \sqrt{(0.4)^2 + (0.4)^2} = 0.566 \text{ m}$$

$$\text{Perimeter of Triangles} = 4 * 0.566 = 2.26 \text{ m}$$

$$\text{Perimeter of half-circle} = \frac{1}{2} * \Pi * 2 * \text{Radius or } \frac{1}{2} * \Pi * \text{Diameter}$$

$$\text{Perimeter of half-circle} = \frac{1}{2} * \Pi * 1.2 = 1.88 \text{ m}$$

$$\text{Total Perimeter} = 7.74 \text{ m}$$

7. Which type of material will you use for the body of your rover (see Table 1)? Why? What is the total cost and weight of the body? How much weight can it hold?

Material: **Honeycomb Core**

Cost: **\$147,825**

Weight: **15.60375 kg**

Strength: **26.28 kg**

Why: **The Honeycomb Core material is capable of holding a lot of weight, which means I can use more instruments. It is also less expensive than Funky Carbon, which has the same strength capabilities. The only concern I had was its weight, but it is less than the required 16 kg. Therefore by comparing price and capabilities the Honeycomb Core is the best material for the rover.**

8. What is the total cost of your rover?

Cost Before Adjustments: **\$1,653,571**

Can the body of your rover support all of the instruments you planned on using? Can you still afford all of the instruments? If not, how will you alter your design plans to fit your constraints?

In order to meet my budget constraints I will take out the Mössbauer Spectrometer. By removing this camera the detail in the study of Martian rocks will decrease and therefore I will have to be more cautious with the readings of rocks I will get from the X-Ray spectrometer. Also, I won't be able to have a back-up camera so I need to make sure that the X-Ray spectrometer doesn't break. After removing the Mössbauer Spectrometer the cost for all the instruments is \$904,738.

Cost After Adjustments: **\$1,435,315**

9. Draw a complete design of your Mars Rover in the space provided. Use the body you designed as the base and determine where the instruments will attach, how the body

will sit on the wheels, where the required components will go, etc. Label the parts of your Rover and the dimensions of the major parts.

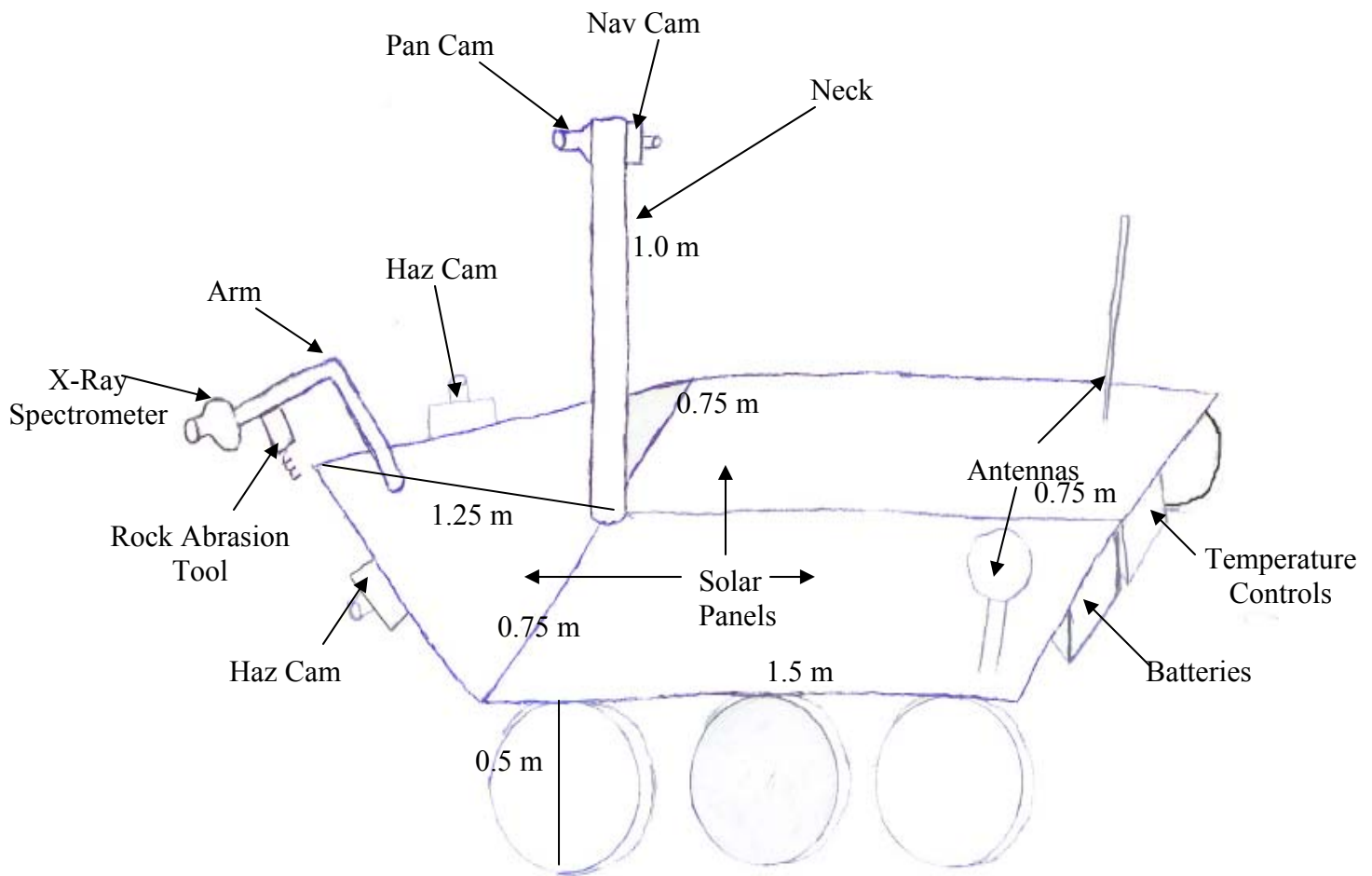

Note: The number of components that are required to have dimensions is at the discretion of the Teacher.

10. What materials (candy) are you planning on using for your wheels, body, and instruments?

Component	Material (Candy type)
Body	Graham Crackers
Wheels	Oreos
Neck	Kit Kat
Panoramic Camera	Marshmallow
Hazard Avoidance Cameras	Jelly Beans

Navigation Cameras	M&Ms
Rock Abrasion tool	A piece of fruit roll up
X-Ray Spectrometer	Gumdrops
Robotic Arm	Toothpicks
Solar Panels	Hershey's chocolate bar
Batteries	Tootsie Rolls
Antennas	Straws
Temperature Controls	Licorice

11. What steps will you follow to build your rover?

First of all, I plan on laying down a heavy coat of frosting for the Rover to stand on. Then I will place the wheels on the frosting and connect the body to the wheels with frosting. Next, I will secure the arm on the body by laying a solar panel (chocolate bar) over the back end and using icing. I will then proceed to connect the spectrometer and rock abrasion tool to the arm by sticking them on the end of the toothpick. I will attach the neck using frosting and more solar panels and place the Pan cam and Nav cam on top. I will connect the batteries and temperature controls to the bottom of the body using frosting. Finally, I will place the solar panels on top with the antennas in between and attach both with frosting.

12. What was the most difficult part of the construction process and how would you do it differently next time?

The Most difficult part of the construction process was attaching the arm. The weight at the end of the arm was a lot for it to support and so it kept falling off. Next time I think I would try to build the body with two layers and choose a stronger material for the arm. That way I could put the arm in between the two layers of graham crackers for more support.

13. Describe any changes you would make to the design process if you were to build another rover.

If I were to build another rover I would try to get a better idea of the general design I was going for before going through the details. I would also choose and design the material first and then pick which instruments I want to use.