

Engineering Fun!

Catapult Presentation



Catapult

- What are some key design goals when designing a catapult?
- What angle should be used to launch an object the farthest?

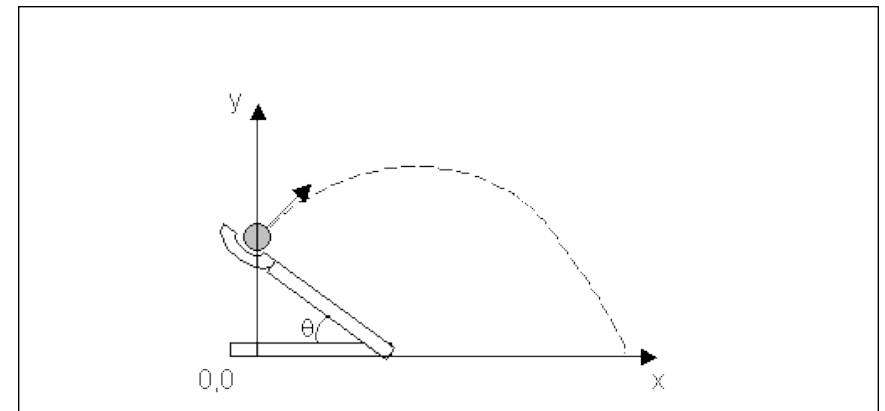

Accuracy vs. Precision

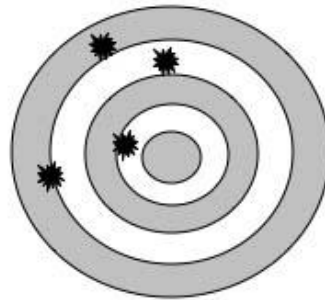

**Not Accurate
Not Precise**

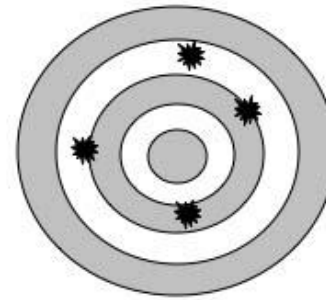

**Accurate
Not Precise**

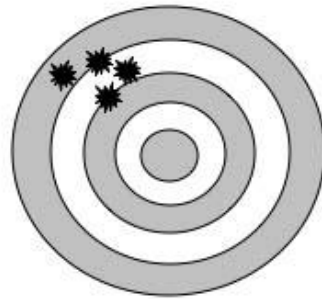

**Not Accurate
Precise**

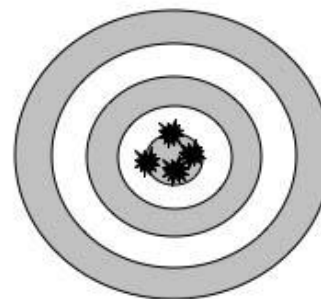

**Accurate
Precise**

Upcoming Activity!

- Goal: Build a catapult that can launch a ping pong ball so that it hits the targets in our game
- Given: Popsicle sticks, straws, rubber bands, spoon, tape and scissors
- Test: Hit as many of the targets as possible in as few shots as possible